

P2560B

Product Preview

Low Frequency EMI Reduction

Product Description

The P2560B is a versatile spread spectrum frequency modulator designed specifically for a wide range of clock frequencies. It reduces electromagnetic interference (EMI) at the clock source allowing system-wide reduction of EMI of downstream clock and data dependent signals. It allows significant system cost savings by reducing the number of circuit board layers and shielding traditionally required to pass EMI regulations.

The P2560B modulates the output of a single PLL in order to spread the bandwidth of a synthesized clock, thereby decreasing the peak amplitudes of its harmonics.

This results in significantly lower system EMI compared to the typical narrow band signal produced by oscillators and most clock generators. Lowering EMI by increasing a signal's bandwidth is called spread spectrum clock generation.

The P2560B uses the most efficient and optimized modulation profile approved by the FCC and is implemented by using a proprietary all-digital method.

Applications

The P2560B is targeted toward the notebook VGA chip and other displays using an LVDS interface, PC peripheral devices, and embedded systems.

Features

- FCC Approved Method of EMI Attenuation
- Generates a Low EMI Spread Spectrum and a Non Spread Reference Signal of the Input Clock Frequency
- Optimized for Input Frequency Range from 20 to 32 MHz
- Internal Loop Filter Minimizes External Components and Board Space
- Two Selectable Spread Ranges
- 3.3 V Operating Voltage
- Ultra Low Power CMOS Design: 5.50 mA @ 3.3 V
- Supports Notebook VGA and Other LCD Timing Controller Applications
- Available in 8-pin SOIC and TSSOP
- These are Pb-Free Devices

This document contains information on a product under development. ON Semiconductor reserves the right to change or discontinue this product without notice.



ON Semiconductor®

<http://onsemi.com>



SOIC-8
S SUFFIX
CASE 751BD



TSSOP-8
T SUFFIX
CASE 948AL

PIN CONFIGURATION

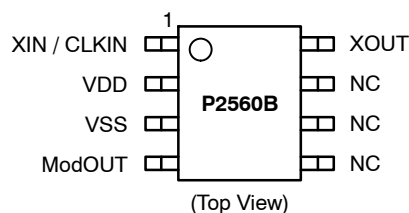

(Top View)

ORDERING INFORMATION

See detailed ordering and shipping information in the package dimensions section on page 6 of this data sheet.

P2560B

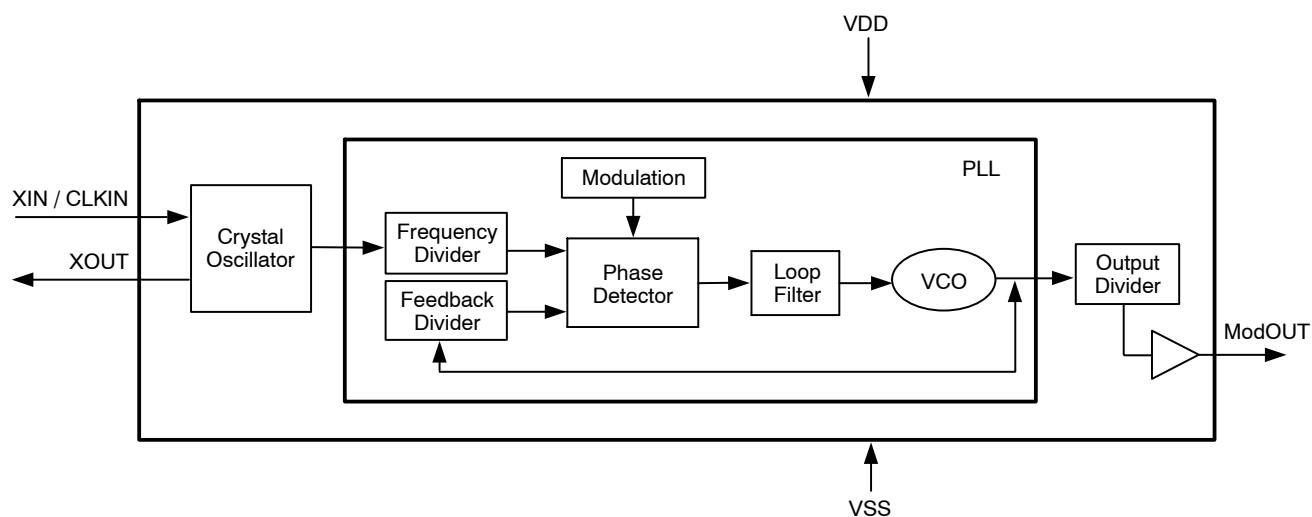

Figure 1. Block Diagram

Table 1. ABSOLUTE MAXIMUM RATINGS

Symbol	Parameter	Rating	Unit
V _{DD} , V _{IN}	Voltage on any pin with respect to Ground	-0.5 to +4.6	V
T _{STG}	Storage temperature	-65 to +125	°C
T _A	Operating temperature	-40 to +85	°C
T _s	Max. Soldering Temperature (10 sec)	260	°C
T _J	Junction Temperature	150	°C
T _{DV}	Static Discharge Voltage (As per JEDEC STD 22- A114-B)	2	KV

Stresses exceeding Maximum Ratings may damage the device. Maximum Ratings are stress ratings only. Functional operation above the Recommended Operating Conditions is not implied. Extended exposure to stresses above the Recommended Operating Conditions may affect device reliability.

Table 2. PIN DESCRIPTION

Pin#	Pin Name	Type	Description
1	XIN / CLKIN	I	Crystal Connection or external frequency input. This pin has dual functions. It can be connected to either an external crystal or an external reference clock.
2	VDD	P	Power Supply for the entire chip.
3	VSS	P	Ground to entire chip.
4	ModOUT	O	Spread spectrum low EMI output.
5	NC	-	No Connect.
6	NC	-	No Connect.
7	NC	-	No Connect.
8	XOUT	O	Crystal Connection. If using an external reference, this pin must be left unconnected.

Table 3. SPREAD RANGE SELECTION, VDD = 3.3 V

CLKIN Frequency	Spreading Range	Modulation Rate
20 MHz	±1.16%	(CLKIN/10) * 20.83 kHz
25 MHz	±1.13%	
27 MHz	±1.11%	
30 MHz	±1.10%	
32 MHz	±1.10%	

P2560B

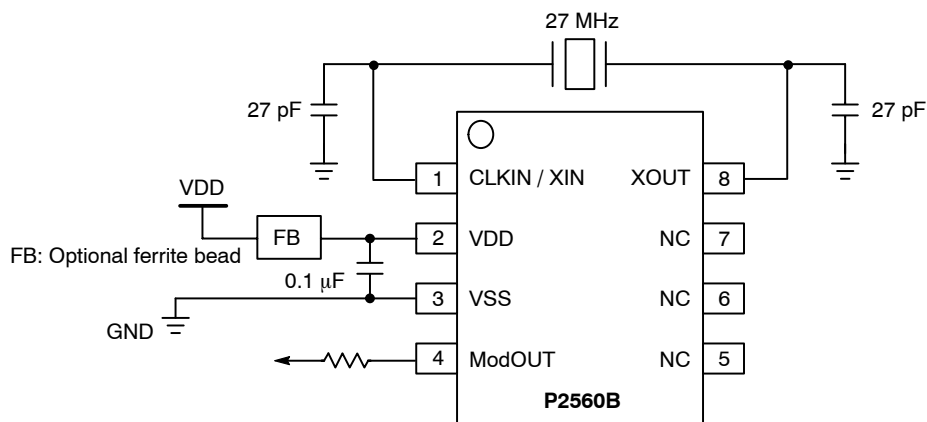

Figure 2. Schematic for Notebook VGA Application

Table 4. DC ELECTRICAL CHARACTERISTICS

Symbol	Parameter		Min	Typ	Max	Unit
V_{IL}	Input Low Voltage		$V_{SS}-0.3$	-	0.8	V
V_{IH}	Input High Voltage		2.0	-	$V_{DD}+0.3$	V
I_{IL}	Input Low current		-60.0	-	-35	μ A
I_{IH}	Input High current		-	-	35	μ A
I_{XOL}	XOUT Output low current	V_{XOL} at 0.4 V, $V_{DD} = 3.3$ V	-	3	-	mA
I_{XOH}	XOUT Output high current	V_{XOH} at 2.5 V, $V_{DD} = 3.3$ V	-	3	-	mA
V_{OL}	Output Low Voltage	$V_{DD} = 3.3$ V, $I_{OH} = 20$ mA	-	-	0.4	V
V_{OH}	Output High Voltage	$V_{DD} = 3.3$ V, $I_{OH} = 20$ mA	2.5	-	-	V
I_{DD}	Static supply current	CLKIN / XIN pulled LOW	-	0.6	-	mA
I_{CC}	Dynamic supply current	3.3 V and 10 pF loading	3.2	-	7.0	mA
V_{DD}	Operating Voltage		3.0	3.3	3.6	V
t_{ON}	Power up time (first locked clock cycle after power up)		-	0.18	-	mS
Z_{OUT}	Clock Output impedance		-	50	-	Ω

Table 5. AC ELECTRICAL CHARACTERISTICS

Symbol	Parameter		Min	Typ	Max	Unit
f_{IN}	Input Frequency		20	-	32	MHz
f_{OUT}	Output Frequency		20	-	32	MHz
t_{LH} (Note 1)	Output Rise time	Measured from 0.8 V to 2.0 V	0.7	0.9	1.1	nS
t_{HL} (Note 1)	Output Fall time	Measured from 2.0 V to 0.8 V	0.6	0.8	1.0	nS
t_{JC}	Jitter (Cycle-to-cycle)		-	-	360	pS
t_D	Output Duty cycle		45	50	55	%

1. t_{LH} and t_{HL} are measured into a capacitive load of 15 pF.

P2560B

PACKAGE DIMENSIONS

TSSOP8, 4.4x3
CASE 948AL-01
ISSUE O

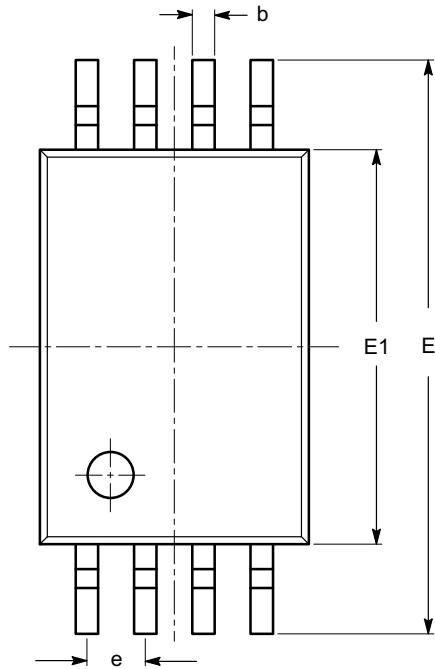

SYMBOL	MIN	NOM	MAX
A			1.20
A1	0.05		0.15
A2	0.80	0.90	1.05
b	0.19		0.30
c	0.09		0.20
D	2.90	3.00	3.10
E	6.30	6.40	6.50
E1	4.30	4.40	4.50
e	0.65 BSC		
L	1.00 REF		
L1	0.50	0.60	0.75
θ	0°		8°

TOP VIEW

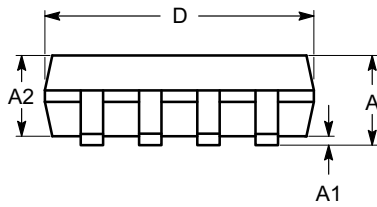

SIDE VIEW

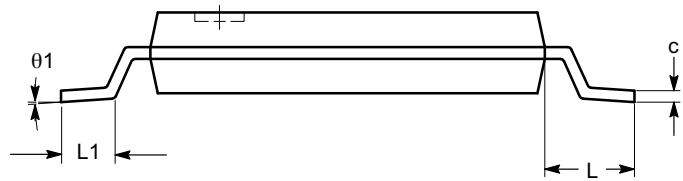

END VIEW

Notes:

- (1) All dimensions are in millimeters. Angles in degrees.
- (2) Complies with JEDEC MO-153.

P2560B

PACKAGE DIMENSIONS

SOIC 8, 150 mils
CASE 751BD-01
ISSUE O

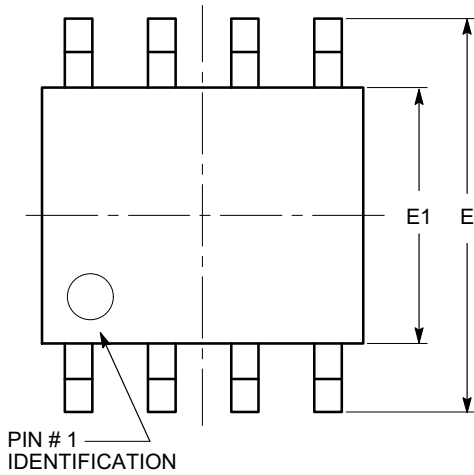

TOP VIEW

SYMBOL	MIN	NOM	MAX
A	1.35		1.75
A1	0.10		0.25
b	0.33		0.51
c	0.19		0.25
D	4.80		5.00
E	5.80		6.20
E1	3.80		4.00
e	1.27 BSC		
h	0.25		0.50
L	0.40		1.27
θ	0°		8°

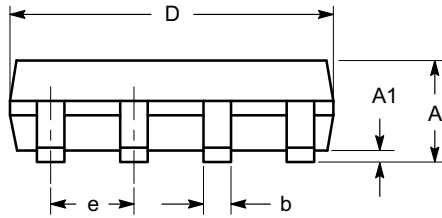

SIDE VIEW

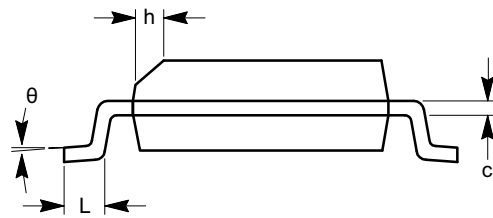

END VIEW

Notes:

- (1) All dimensions are in millimeters. Angles in degrees.
- (2) Complies with JEDEC MS-012.

P2560B

Table 6. ORDERING INFORMATION

Part Number	Marking	Package Type	Temperature
P2560BG-08ST	P2560BG	8-Pin SOIC, Tube, Green	Commercial
P2560BG-08SR	P2560BG	8-Pin SOIC, Tape and Reel, Green	Commercial
I2560BG-08ST	I2560BG	8-Pin SOIC, Tube, Green	Industrial
I2560BG-08SR	I2560BG	8-Pin SOIC, Tape and Reel, Green	Industrial
P2560BG-08TT	P2560BG	8-Pin TSSOP, Tube, Green	Commercial
P2560BG-08TR	P2560BG	8-Pin TSSOP, Tape and Reel, Green	Commercial
I2560BG-08ST	I2560BG	8-Pin TSSOP, Tube, Green	Industrial
I2560BG-08SR	I2560BG	8-Pin TSSOP, Tape and Reel, Green	Industrial

ON Semiconductor and  are registered trademarks of Semiconductor Components Industries, LLC (SCILLC). SCILLC reserves the right to make changes without further notice to any products herein. SCILLC makes no warranty, representation or guarantee regarding the suitability of its products for any particular purpose, nor does SCILLC assume any liability arising out of the application or use of any product or circuit, and specifically disclaims any and all liability, including without limitation special, consequential or incidental damages. "Typical" parameters which may be provided in SCILLC data sheets and/or specifications can and do vary in different applications and actual performance may vary over time. All operating parameters, including "Typicals" must be validated for each customer application by customer's technical experts. SCILLC does not convey any license under its patent rights nor the rights of others. SCILLC products are not designed, intended, or authorized for use as components in systems intended for surgical implant into the body, or other applications intended to support or sustain life, or for any other application in which the failure of the SCILLC product could create a situation where personal injury or death may occur. Should Buyer purchase or use SCILLC products for any such unintended or unauthorized application, Buyer shall indemnify and hold SCILLC and its officers, employees, subsidiaries, affiliates, and distributors harmless against all claims, costs, damages, and expenses, and reasonable attorney fees arising out of, directly or indirectly, any claim of personal injury or death associated with such unintended or unauthorized use, even if such claim alleges that SCILLC was negligent regarding the design or manufacture of the part. SCILLC is an Equal Opportunity/Affirmative Action Employer. This literature is subject to all applicable copyright laws and is not for resale in any manner.

PUBLICATION ORDERING INFORMATION

LITERATURE FULFILLMENT:

Literature Distribution Center for ON Semiconductor
P.O. Box 5163, Denver, Colorado 80217 USA
Phone: 303-675-2175 or 800-344-3860 Toll Free USA/Canada
Fax: 303-675-2176 or 800-344-3867 Toll Free USA/Canada
Email: orderlit@onsemi.com

N. American Technical Support: 800-282-9855 Toll Free
USA/Canada
Europe, Middle East and Africa Technical Support:
Phone: 421 33 790 2910
Japan Customer Focus Center
Phone: 81-3-5773-3850

ON Semiconductor Website: www.onsemi.com

Order Literature: <http://www.onsemi.com/orderlit>

For additional information, please contact your local Sales Representative